

Solenoid valve(3/2 way)

3V2 Series

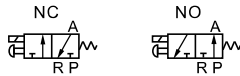

Symbol



Product feature

1. Direct acting type and normally closed mode, flexible in direction change.
2. Normally closed and normally open types are optional.
3. Structure in coaxial blanking mode: leakage proof and large air flow.
4. No need to add oil for lubrication.
5. Affiliated manual devices are equipped to facilitate installation and debugging.
6. Several standard voltage grades are optional.
7. Can be used under vacuum condition.

Ordering code

Ordering code of solenoid valve

3V 2 08 NC A □ G

① ② ③ ④ ⑤ ⑥ ⑦

① Model	② Code	③ Port size	④ Acting type	⑤ Standard voltage	⑥ Electrical entry	⑦ Thread type
3V: Solenoid valve(3/2 way)	2: 2 Series	06: 1/8" 08: 1/4"	NC: Normally closed NO: Normally opened	A: AC220V B: DC24V C: AC110V E: AC24V F: DC12V	Blank: Terminal I: Grommet	G: G

Ordering code of accessories

F-3V2 FA

① ② ③

① Accessories code	② Valve type	③ Accessories type
F: Mounting accessories	3V2: Solenoid valve(3/2 way)	FA: FA Bracket

Flow chart

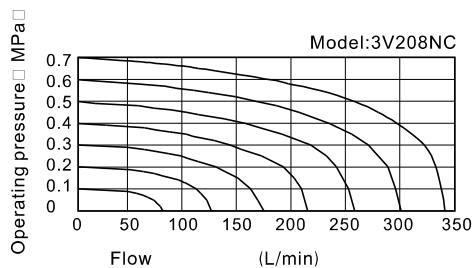

Inner structure

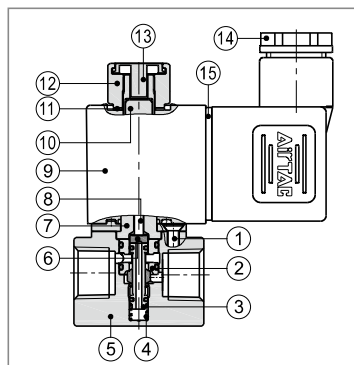

No.	Item	No.	Item
1	Pilot screw	9	Coil
2	Spacer	10	Armature
3	Spool	11	Washer
4	Spring	12	Coil nut
5	Body	13	Manual button
6	Washer	14	Connector
7	Electromagnet set	15	Gasket
8	Man drill		

Specification

Model	3V206	3V208
Fluid	Air(to be filtered by 40 μm filter element)	
Acting	Direct acting	
Port size [Note1]	1/8"	1/4"
Valve type	3 port 2 position	
Orifice size	3.2mm ² (Cv=0.18)	3.4mm ² (Cv=0.19)
Lubrication	Not required	
Operating pressure	Common 0~0.8MPa(0~114psi) vacuum -102.2kPa~0.1MPa(-1.45~14.2psi)	
Proof pressure	1.2MPa(175psi)	
Temperature	-20~70°C	
Material of body	Aluminum alloy	

[Note1] G thread is available.

Coil specification

Item	Specification
Standard voltage	AC220V, AC110V, AC24V, DC24V, DC12V
Scope of voltage	AC: ±15% DC: ±10%
Power consumption	AC: 7VA DC: 7.0W
Protection	IP65(DIN40050)
Temperature classification	B Class
Electrical entry	Terminal, Grommet
Activating time	0.05 sec and below
Max. frequency [Note1]	10 cycle/sec

[Note1] The maximum actuation frequency is in the no-load state.

Solenoid valve(3/2 way)

3V2 Series

Dimensions

Terminal

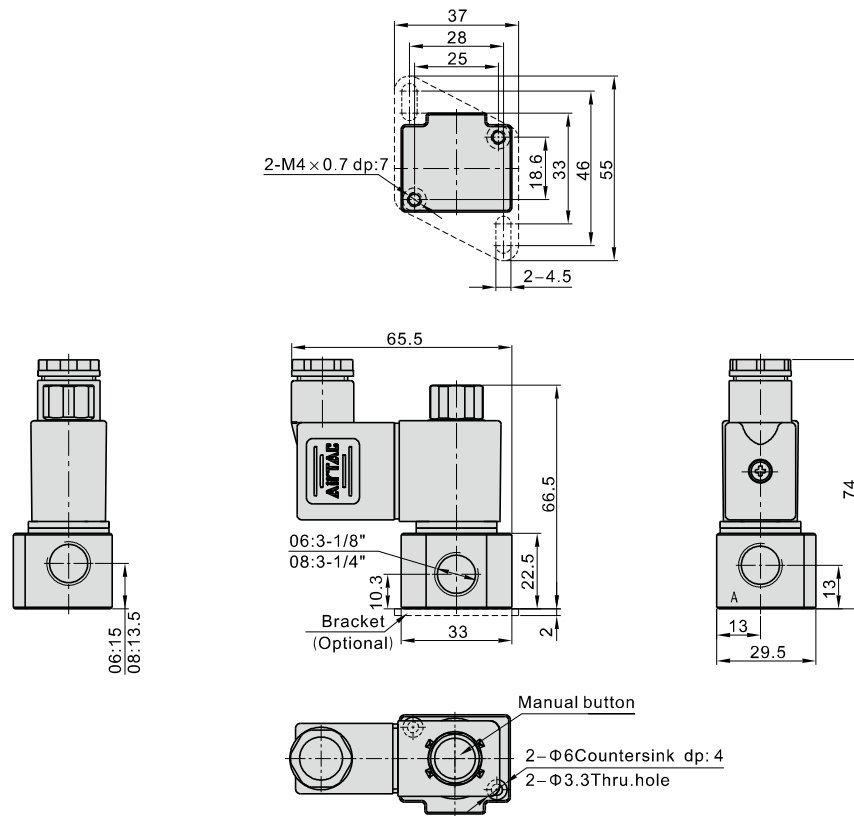

Grommet

