

ISO15552 Standard cylinder

SAI Series—Accessories

List for ordering code of accessories

Accessories Bore size	Mounting accessories								
	LB	FA/FB	CA	CB	CR	TC	FTC	TCM1	TCM2
32	F-SI32LB	F-SI32FA	F-SE32CA	F-SE32CB	F-SI32CR	F-SAI32TC	F-SI32FTC	F-SI32TCM1	F-SI32TCM2
40	F-SI40LB	F-SI40FA	F-SE40CA	F-SE40CB	F-SI40CR	F-SAI40TC	F-SI40FTC	F-SI40TCM1	F-SI40TCM2
50	F-SI50LB	F-SI50FA	F-SE50CA	F-SE50CB	F-SI50CR	F-SAI50TC	F-SI50FTC	F-SI40TCM1	F-SI40TCM2
63	F-SI63LB	F-SI63FA	F-SE63CA	F-SE63CB	F-SI63CR	F-SAI63TC	F-SI63FTC	F-SI63TCM1	F-SI63TCM2
80	F-SI80LB	F-SI80FA	F-SE80CA	F-SE80CB	F-SI80CR	F-SAI80TC	F-SI80FTC	F-SI63TCM1	F-SI63TCM2
100	F-SI100LB	F-SI100FA	F-SE100CA	F-SE100CB	F-SI100CR	F-SAI100TC	F-SI100FTC	F-SI125TCM1	F-SI125TCM2
125	F-SI125LB	F-SI125FA	F-SE125CA	F-SE125CB	F-SI125CR	F-SAI125TC	F-SI125FTC	F-SI125TCM1	F-SI125TCM2
160	F-SI160LB	F-SI160FA	F-SI160CA	F-SI160CB	F-SI160CR	F-SI160TC	F-SI160FTC	F-SI160TCM1	F-SI160TCM2
200	F-SI200LB	F-SI200FA	F-SI200CA	F-SI200CB	F-SI200CR	F-SI200TC	F-SI200FTC	F-SI200TCM1	F-SI160TCM2

Accessories Bore size	Knuckle				Sensor switch	
	I	Y	F	U	CMSE	DMSE
32	F-M10X125I	F-M10X125Y	F-M10X125F	F-M10X125U	CMSE	DMSE
40	F-M12X125I	F-M12X125Y	F-M12X125F	F-M12X125U		
50	F-M16X150I	F-M16X150Y	F-M16X150F	F-M16X150U		
63	F-M16X150I	F-M16X150Y	F-M16X150F	F-M16X150U		
80	F-M20X150I	F-M20X150Y	F-M20X150F	F-M20X150U		
100	F-M20X150I	F-M20X150Y	F-M20X150F	F-M20X150U		
125	F-M27X200I	F-M27X200Y	F-M27X200F	F-M27X200U		
160	F-M36X200I	F-M36X200Y	F-M36X200F	F-M36X200U		
200	F-M36X200I	F-M36X200Y	F-M36X200F	F-M36X200U		

Accessory selection

Accessories Cylinder model	Mounting accessories										Knuckle [Note1]				Sensor switch	
	LB	FA	FB	CA	CB	CR	TC	FTC	TCM1	TCM2	I	Y	U	F	CMSE	DMSE
SAI	Standard	●	●	●	●	●	●	●	●	●	●	●	●	●	×	×
	With magnet	●	●	●	●	●	●	●	●	●	●	●	●	●	●	●
SAIL	Standard	●	●	●	●	●	●	×	●	●	●	●	●	●	×	×
	With magnet	●	●	●	●	●	●	×	●	●	●	●	●	●	●	●
BSAI	Standard	●	●	●	●	●	●	×	●	●	●	●	●	●	×	×
	With magnet	●	●	●	●	●	●	×	●	●	●	●	●	●	●	●
SAID	Standard	●	●	×	×	×	×	●	●	●	●	●	●	●	×	×
	With magnet	●	●	×	×	×	×	●	●	●	●	●	●	●	●	●
BSAID	Standard	●	●	×	×	×	×	●	×	●	●	●	●	●	×	×
	With magnet	●	●	×	×	×	×	●	×	●	●	●	●	●	●	●
SAIJ	Standard	●	●	×	×	×	×	●	●	●	●	●	●	●	×	×
	With magnet	●	●	×	×	×	×	●	●	●	●	●	●	●	●	●

[Note1] Please refer to P515~518 for knuckle detail.

Material of accessories

Accessories Bore size	Mounting accessories										Knuckle			
	LB	FA	FB	CA	CB	CR	TC	FTC	TCM1	TCM2	I	Y	F	U
32~100	○	●	●	◇	◇	◇	◇	■	■	●	□	□	□	□
125~200	□	□	□	□	□	□	□	□	□	●	□	□	□	□

●—Aluminum alloy, ■—Cast steel, ○—Low carbon steel, ◇—Nodular cast iron, □—Carbon steel.

ISO15552 Standard cylinder

SAI Series—Accessories

Dimensions

LB

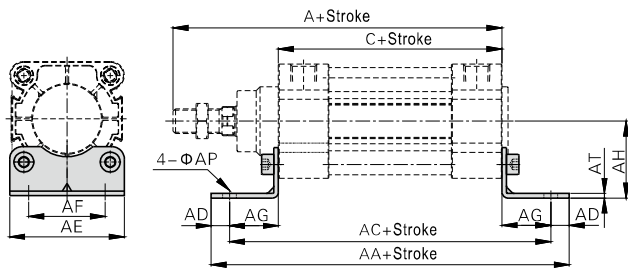

Bore size/Item	A	C	AA	AC	AD	AE	AF	AG	AH	AP	AT
32	142	94	158	142	8	47	32	24	32	7	3
40	159	105	179	161	9	53	36	28	36	9	3
50	175	106	190	170	10	65	45	32	45	9	3
63	190	121	209	185	12	75	50	32	50	9	3
80	214	128	248	210	19	95	63	41	63	12.5	4
100	229	138	266	220	19	115	75	41	71	14.5	4
125	279	160	290	250	20	140	90	45	90	16.5	8
160	332	180	340	300	20	180	115	60	115	18.5	8
200	347	180	380	320	30	220	135	70	135	24	9

CA

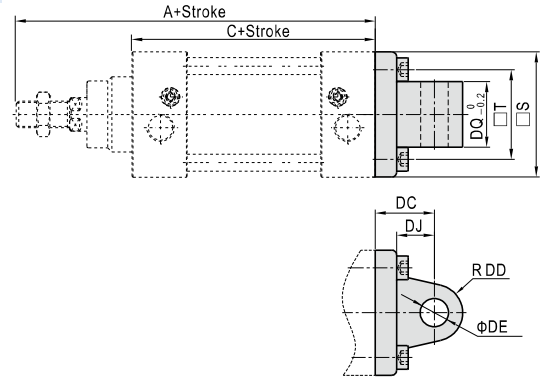

Bore size/Item	A	C	S	T	DC	DD	DE	DJ	DQ
32	142	94	47	32.5	22	9	10	13	25.8
40	159	105	52	38	25	10.5	12	16	27.8
50	175	106	64	46.5	27	11	12	17	31.7
63	190	121	74	56.5	32	13.5	16	22	39.7
80	214	128	94	72	36	14.5	16	22	49.7
100	229	138	113	89	41	17	20	27	59.7
125	279	160	139	110	50	22	25	33	69.7
160	332	180	180	140	55	30	30	35.5	89.7
200	347	180	220	175	60	30	30	37	89.7

FA/FB

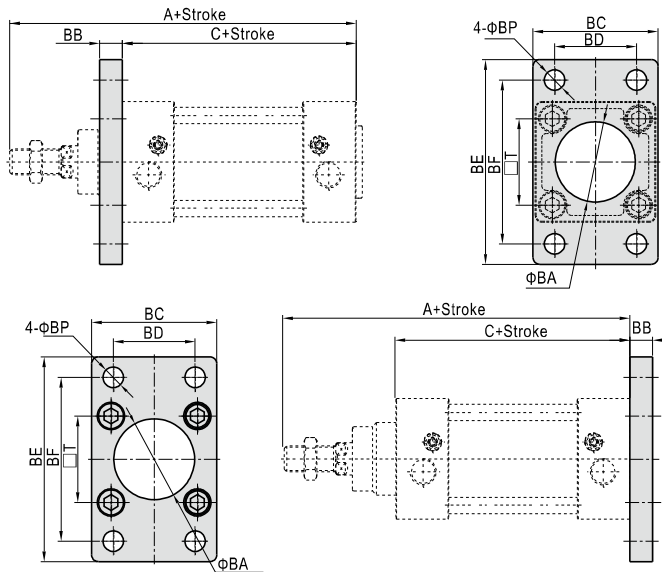

Bore size/Item	A	C	BA	BB	BC	BD	BE	BF	BP	T
32	142	94	30.5	10	47	32	80	64	7	32.5
40	159	105	35.5	10	53	36	90	72	9	38
50	175	106	40.5	12	65	45	108	90	9	46.5
63	190	121	45.5	12	75	50	118	100	9	56.5
80	214	128	45.5	16	95	63	150	126	12.5	72
100	229	138	55.5	16	115	75	176	150	14.5	89
125	279	160	60.5	20	139	90	218	180	16.5	110
160	332	180	65.5	20	180	115	280	230	18.5	140
200	347	180	75.5	25	220	135	320	270	24	175

CB

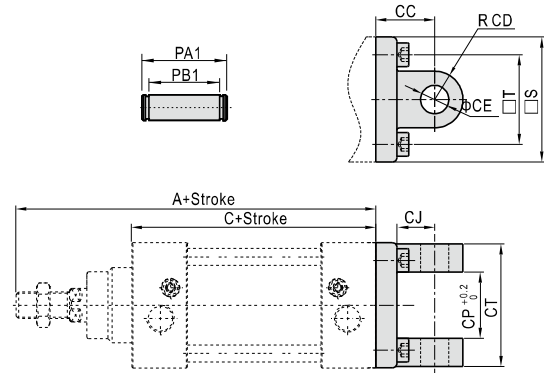

Bore size/Item	A	C	CC	CD	CE	CJ	CP	CT	PA1	PB1	S	T
32	142	94	22	9	10	13	26	45	51	45.5	47	32.5
40	159	105	25	10.5	12	16	28	52	59	52.5	52	38
50	175	106	27	11	12	17	32	60	67	60.5	64	46.5
63	190	121	32	13	16	22	40	70	77	70.5	74	56.5
80	214	128	36	14	16	22	50	90	97	90.5	94	72
100	229	138	41	17.5	20	27	60	110	119	110.5	113	89
125	279	160	50	21.5	25	33	70	130	139	130.5	139	110
160	332	180	55	30	30	35.5	90	170	181	170.5	180	140
200	347	180	60	30	30	36	90	170	181	170.5	220	175

ISO1552 Standard cylinder



SAI Series—Accessories

TC

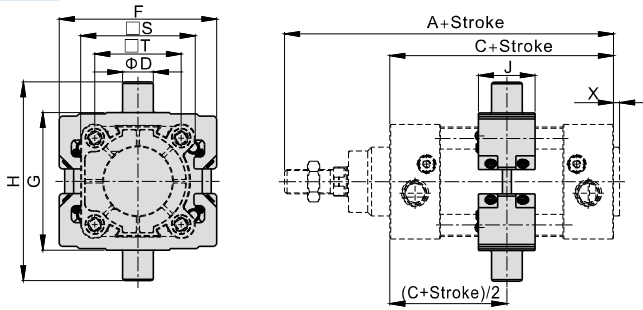

Bore size/Item	A	C	D	F	G	H	J	S	X	T
32	142	94	12	65	52	76	31	47	3	32.5
40	159	105	16	75	63	95	31	53	3.5	38
50	175	106	16	91	75	107	35	65	3.5	46.5
63	190	121	20	103	90	130	35	75	4	56.5
80	214	128	20	126	110	150	45	95	4	72
100	229	138	25	145	132	182	45	115	4	89
125	279	160	25	175	160	210	51	140	4	110
160	332	180	32	210	200	264	50	180	4	140
200	347	180	32	255	250	314	50	220	5	175

[Note] 160 and 200 TC accessory has been installed on the barrel of cylinder before it worked off, and the position of the accessories can not be adjusted arbitrarily. If consumer orders the TC solely, he will not install it on the barrel of standard cylinder directly.

FTC

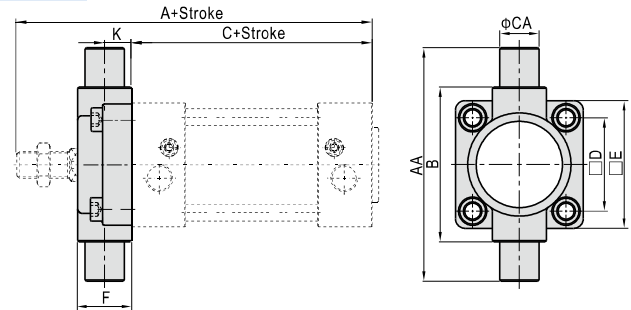

Bore size/Item	A	C	AA	B	CA	D	E	F	K
32	142	94	74	50	12	32.5	46	19	10
40	159	105	95	63	16	38	52	21	10
50	175	106	107	75	16	46.5	64	26	12
63	190	121	130	90	20	56.5	74	28	12
80	214	128	150	110	20	72	94	31	16
100	229	138	182	132	25	89	114	35	16
125	279	160	210	160	25	110	139	43	20
160	332	180	264	200	32	140	179	56	20
200	347	180	314	250	32	175	218	64	20

TCM1

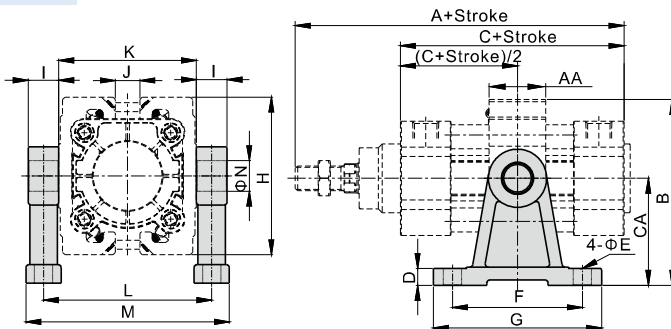

Bore size/Item	A	C	AA	B	CA	D	E	F	G	H	I	J	K	L	M	N
32	142	94	31	72.5	40	11	9	60	80	65	12	5	52	64	79	12
40	159	105	31	91.5	54	11	12	75	100	75	16	8	63	79	98	16
50	175	106	35	99.5	54	11	12	75	100	91	16	10	75	91	110	16
63	190	121	35	121.5	70	11	12	85	110	103	20	16	90	110	133	20
80	214	128	45	133	70	11	12	85	110	126	20	20	110	130	153	20
100	229	138	45	162.5	90	19	18	115	155	145	25	28	132	157	185	25
125	279	160	51	177.5	90	19	18	115	155	175	25	40	160	185	213	25
160	332	180	50	215	110	24	22	140	190	210	32	100	200	232	267	32
200	347	180	50	262.5	135	27	22	150	200	255	32	125	250	282	317	32

[Note] 160/200 installation position of the accessories can not be adjusted arbitrarily. When TCM1 be used with FTC, please refer to page 245.

TCM2

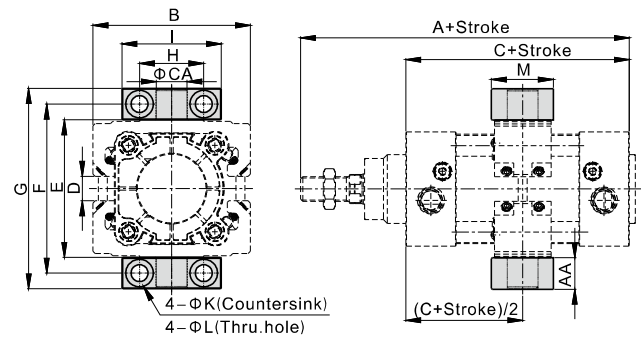

Bore size/Item	A	AA	B	C	CA	D	E	F	G	H	I	K	L	M
32	142	14	65	94	12	5	52	68	82	32	46	11	7	30
40	159	17	75	105	16	8	63	82	99	36	55	15	9	36
50	175	17	91	106	16	10	75	94	111	36	55	15	9	36
63	190	20.5	103	121	20	16	90	113.5	134	42	65	18	11	40
80	214	20.5	126	128	20	20	110	133.5	154	42	65	18	11	40
100	229	24.5	145	138	25	28	132	159.5	184	50	75	20	14	50
125	279	24.5	175	160	25	40	160	187.5	212	50	75	20	14	50
160	332	30	210	180	32	100	200	234	264	60	92	26	18	60
200	347	30	255	180	32	125	250	284	314	60	92	26	18	60

[Note] 160/200 installation position of the accessories can not be adjusted arbitrarily. When TCM2 be used with FTC, please refer to page 245.

CR

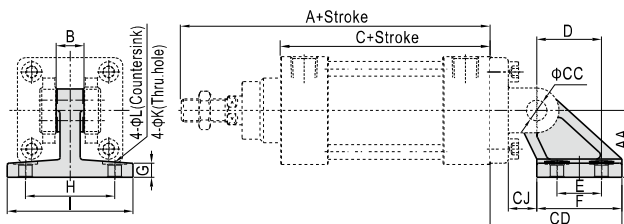

Bore size/Item	A	AA	B	C	CC	CD	CJ	D	E	F	G	H	I	K	L
32	142	32	26	94	10	50	10	21	18	31	8	38	51	6.6	-
40	159	36	28	105	12	56	12	24	22	35	10	41	54	6.6	-
50	175	45	32	106	12	68	13	33	30	45	12	50	65	9	-
63	190	50	40	121	16	77	17	37	35	50	12	52	67	9	-
80	214	63	50	128	16	93	19	47	40	60	14	66	86	11	18
100	229	71	60	138	20	106	22	55	50	70	15	76	96	11	18
125	279	90	70	160	25	135	26	70	60	90	20	94	124	14	20
160	332	115	90	180	30	171	25	97	88	126	25	118	156	14	20
200	347	135	90	180	30	185	31	105	90	130	30	122	162	18	26

[Note] CR can't be used alone, it must be used with CB.

