

GPR Series Precision Regulator



Specification

Model	GPR20006	GPR30008	GPR40008	GPR40010	GPR40015
Fluid	Air				
Port size [Note1]	1/8"	1/4"	1/4"	3/8"	1/2"
Max. supply pressure	1.0MPa(145psi)				
Operating pressure	Lower pressure	0.005~0.2MPa(0.73~29psi)		0.01~0.2MPa(1.45~29psi)	
	Medium pressure	0.01~0.4MPa(1.45~58psi)			
	High pressure	0.01~0.8MPa(1.45~116psi)			
Sensitivity	Within 0.2%F.S.				
Repeatability	Within ±0.5%F.S.				
Air consumption (ANR)	≤4L/min	≤4L/min	≤9.5L/min	≤11.5L/min	
Temperature range	-20~70°C(Unfreeze)				
Weight	144g	336g	717g		

[Note1] G thread is available.

Symbol



Product feature

1. High pressure regulating accuracy and rapid-response.
2. Good pressure and flow chart.
3. Easy installation, it can be installed independently by bracket or directly with existing filter combination components of module type.
4. In addition to high pressure type, the type of medium pressure and lower pressure can be selected.

Ordering code

GPR300 08 H □ □ G

① ② ③ ④ ⑤ ⑥

① Model	② Port size	③ Regulating pressure range	④ Accessories	⑤ Pressure gauge	⑥ Thread type [Note1]
GPR200: 00 Series Precision Regulator	06: 1/8"	L: 0.005~0.2MPa(0.73~29psi) M: 0.01~0.4MPa(1.45~58psi)	Blank: Bracket J: No bracket	Blank: With pressure gauge N: Without pressure gauge	G: G Thread (Scale:MPa&bar)
GPR300: 300 Series Precision Regulator	08: 1/4"	H: 0.01~0.8MPa(1.45~116psi)			
GPR400: 400 Series Precision Regulator	08: 1/4" 10: 3/8" 15: 1/2"	L: 0.01~0.2MPa(1.45~29psi) M: 0.01~0.4MPa(1.45~58psi) H: 0.01~0.8MPa(1.45~116psi)			

[Note1] Please consult us for special correspondence.

Inner structure

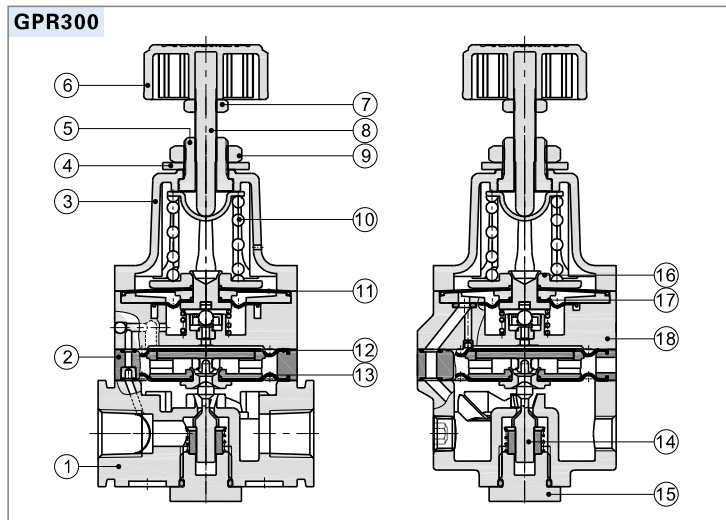

No.	Item	Material
1	Regulator body	Aluminum alloy
2	Pilot body	Plastic
3	Regulator seat	Aluminum alloy
4	Bracket gasket	SPCC
5	Adjusting nut	Carbon steel
6	Regulator knob	Plastic
7	Nut	Carbon steel
8	Regulator spindle	Carbon steel
9	Nut	Carbon steel
10	Spring	Spring steel
11	Pilot upper diaphragm	NBR
12	Regulator upper diaphragm	NBR
13	Regulator lower diaphragm	NBR
14	Main valve	Stainless steel+NBR
15	Bonnet	Carbon steel
16	Pilot diaphragm upper hard core	Aluminum alloy
17	Pilot lower diaphragm	NBR
18	Nozzle body	Aluminum alloy

GPR Series Precision Regulator

Pressure chart

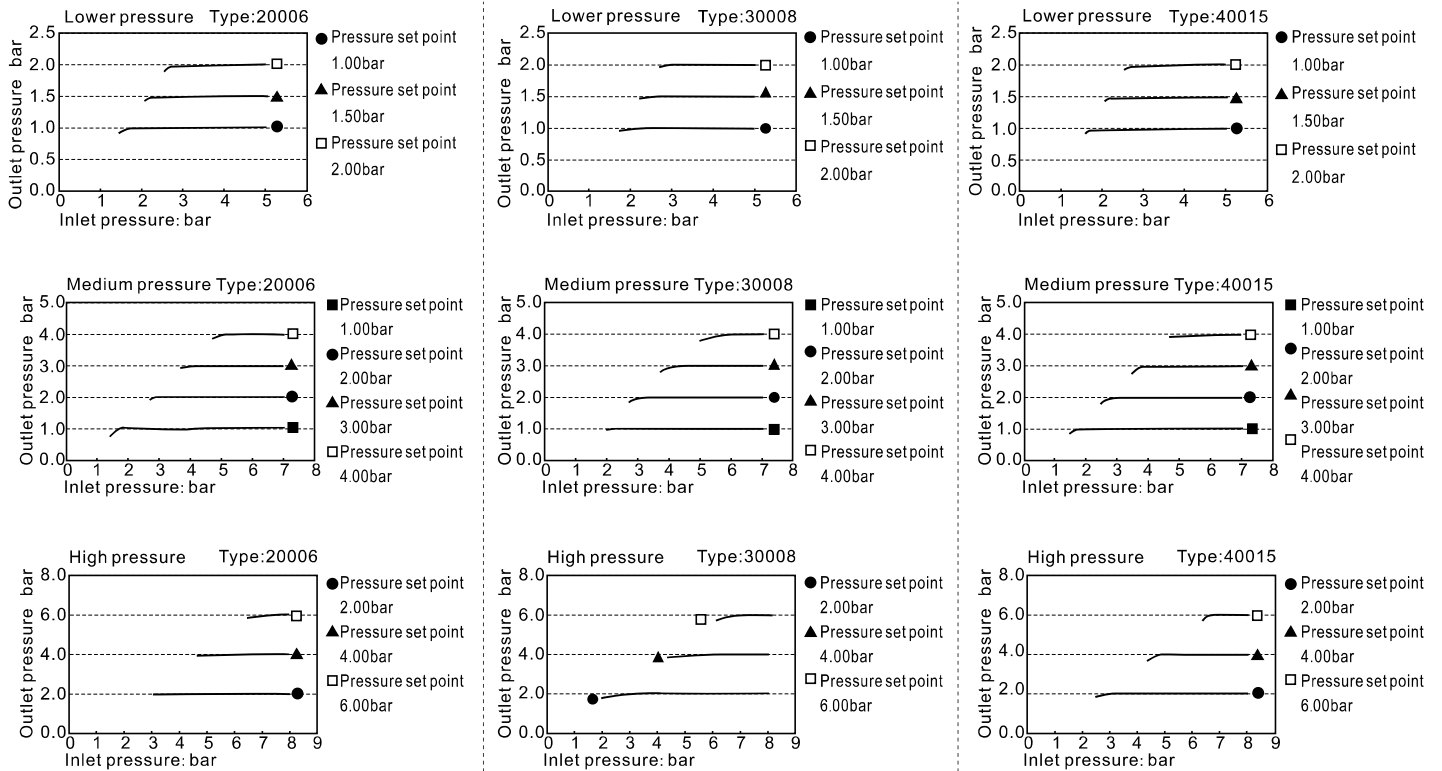

Flow chart

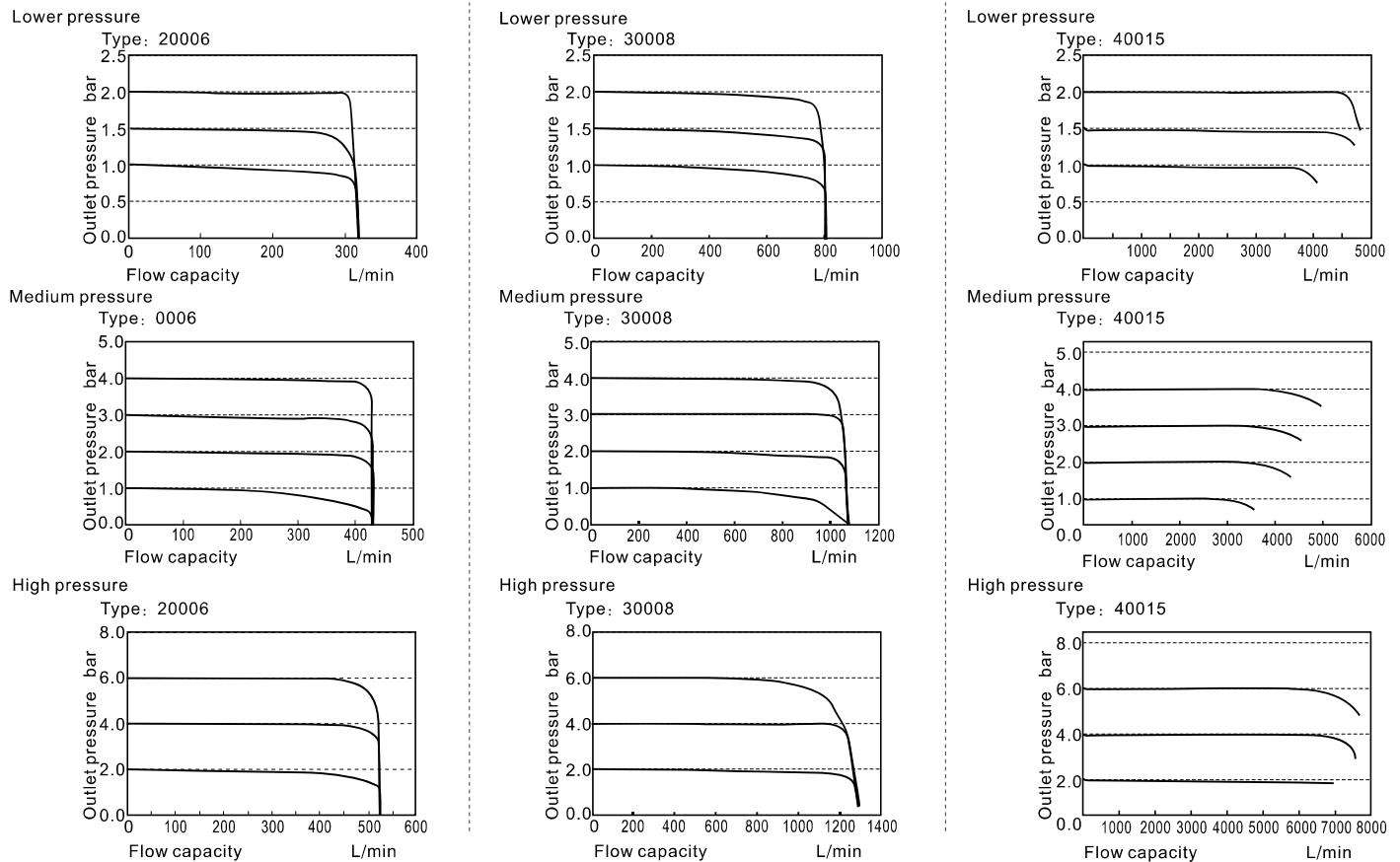

GPR Series Precision Regulator

Overflow chart

Lower pressure

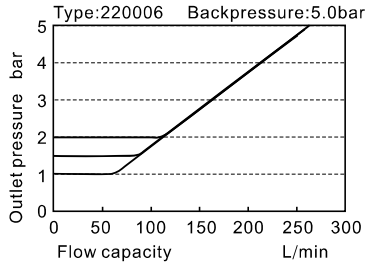

Lower pressure

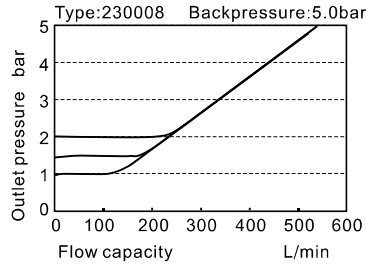

Lower pressure

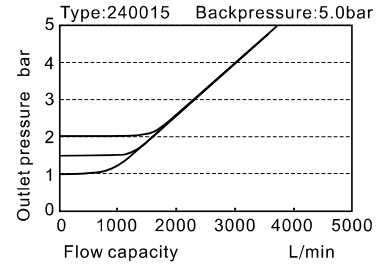

Medium pressure

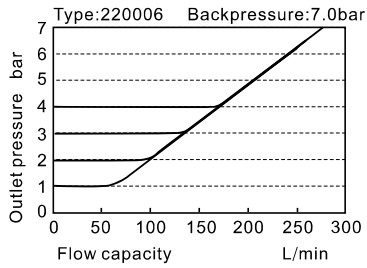

Medium pressure

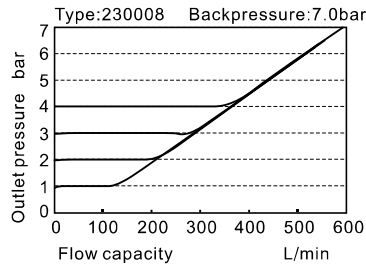

Medium pressure

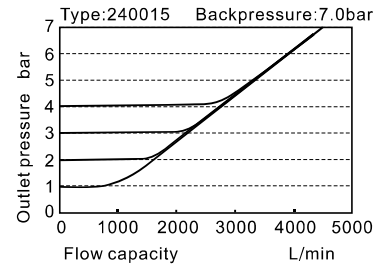

High pressure

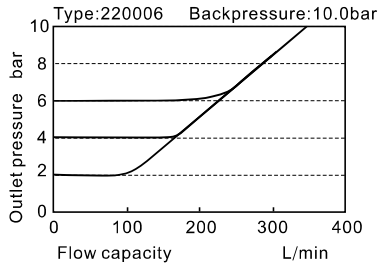

High pressure

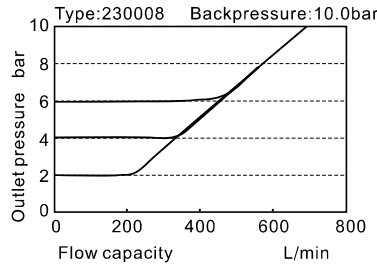

High pressure

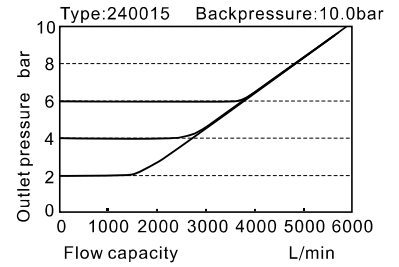

Preparation unit—GP Series

GPR Series Precision Regulator

Dimensions

GPR200

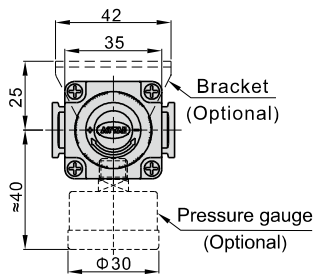
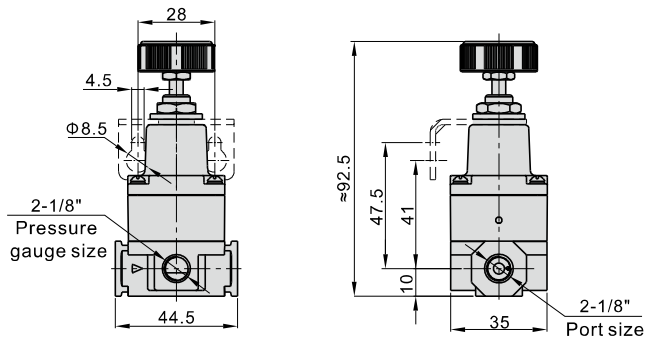

GPR300

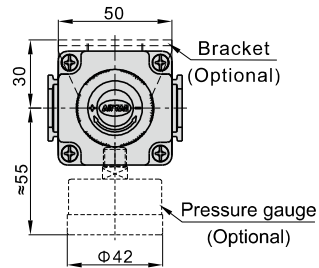
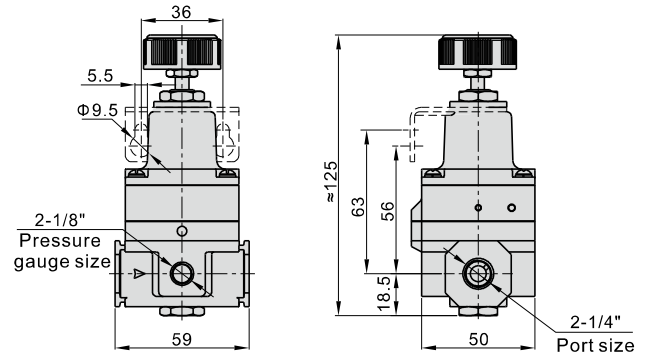

GPR400

